



TURN SHEET SIDEWAYS TO LOCATE YOUR HANGER POSTIONS

16 INCHES FROM CENTER TO CENTER

Instructions for Philips Commercial Bulb Cabinet

Carton Contents

1891CP Standard Mini Bulb	1445CP Standard Mini Bulb	1662CP Standard Mini Bulb	561CP Standard Mini Bulb	90CP Standard Mini Bulb
198CP Standard Mini Bulb	464CP Standard Mini Bulb	9003C1 Standard Halogen	9004C1 Standard Halogen	9005C1 Standard Halogen
9006C1 Standard Halogen	9007C1 Standard Halogen	9008C1 Standard Halogen	9011C1 Standard Halogen	9012LC1 Standard Halogen
H118C1 Standard Halogen	H11C1 Standard Halogen	H7C1 Standard Halogen	H8C1 Standard Halogen	H9C1 Standard Halogen
H1C1 Standard Halogen	H3C1 Standard Halogen			

194CP Standard Mini Bulb	3157CP Standard Mini Bulb	1157CP Standard Mini Bulb	7443CP Standard Mini Bulb	3157NACP Standard Mini Bulb
1156CP Standard Mini Bulb	3057CP Standard Mini Bulb	921CP Standard Mini Bulb	194NACP Standard Mini Bulb	912CP Standard Mini Bulb
3156CP Standard Mini Bulb	166CP Standard Mini Bulb	7440CP Standard Mini Bulb	2057CP Standard Mini Bulb	1157NACP Standard Mini Bulb
67CP Standard Mini Bulb	1893CP Standard Mini Bulb	12814CP Standard Mini Bulb	906CP Standard Mini Bulb	3457CP Standard Mini Bulb
12844CP Standard Mini Bulb	12502CP Standard Mini Bulb	37CP Standard Mini Bulb	1003CP Standard Mini Bulb	1895CP Standard Mini Bulb
1141CP Standard Mini Bulb	PC74CP Standard Mini Bulb	12961CP Standard Mini Bulb	89CP Standard Mini Bulb	12516CP Standard Mini Bulb
53CP Standard Mini Bulb	74CP Standard Mini Bulb	PC194CP Standard Mini Bulb	PC194CP Standard Mini Bulb	57CP Standard Mini Bulb
2357CP Standard Mini Bulb	211-2CP Standard Mini Bulb	922CP Standard Mini Bulb	1142CP Standard Mini Bulb	1078CP Standard Mini Bulb
97CP Standard Mini Bulb	3457NACP Standard Mini Bulb	1683CP Standard Mini Bulb	193CP Standard Mini Bulb	1816CP Standard Mini Bulb
1004CP Standard Mini Bulb	904CP Standard Mini Bulb	3057NACP Standard Mini Bulb	1156NACP Standard Mini Bulb	3156NACP Standard Mini Bulb

One set of I.D. labels for for labeling bins

One Assembled Unit

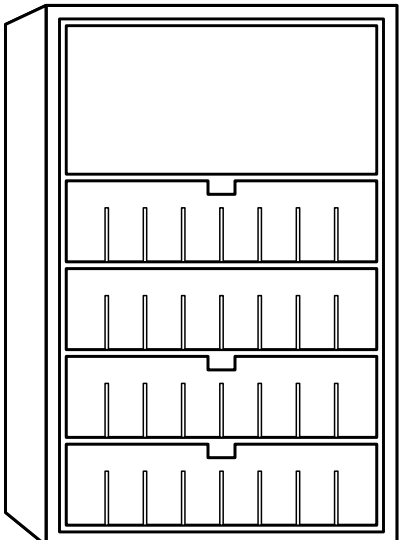

Apply labels provided in numerical sequence on bin fronts

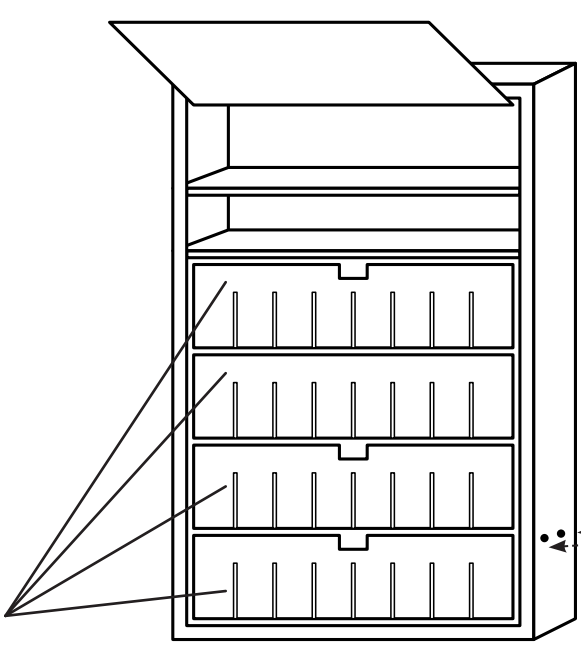

Wire catalog holder with 2 screws

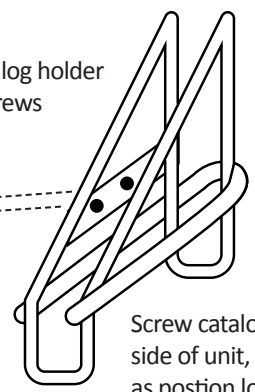

Screw catalog holder onto right side of unit, using holes provided as position locators.

INSERTING PLASTIC TRAYS

INTERNAL CARTON CONTAINS (4) POLYSTYRENE TIP OUT TRAYS

Remove the internal carton, and unpack (4) tip out trays. Beginning at the top, hold the tray with the front notch facing you and the sloped side to the rear as depicted below. Tilt the tray toward you to align Tab A to Slot A. Push the tray back until Tab B on left and right sides align with Slot B, until the tray seats itself in the rear guides and drops into place.

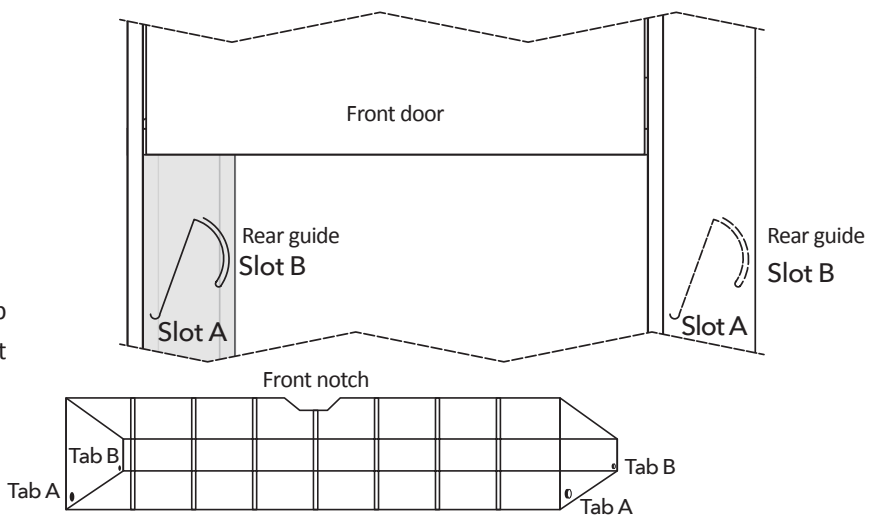

INSERTING PLASTIC DIVIDERS INTO TIP-OUT TRAY

(4) POLYSTYRENE TIP OUT TRAYS WITH (28) DIVIDERS

Each tip out tray has (7) dividers. Install dividers by aligning divider with front and back slots in the tip out tray and slide into position.

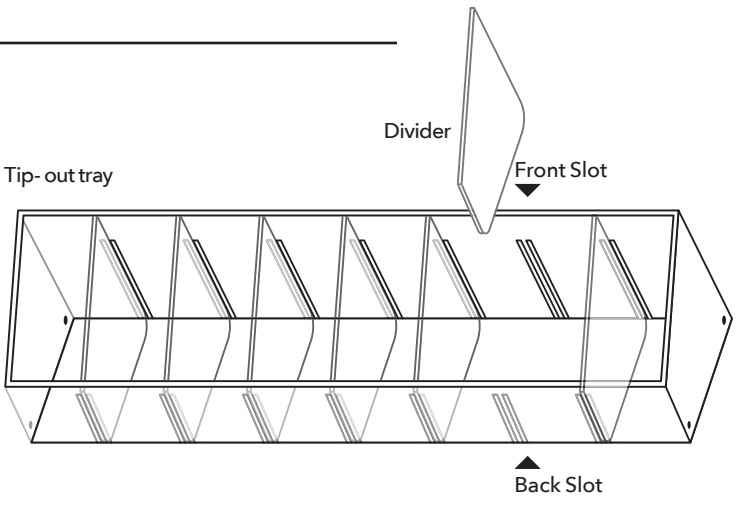
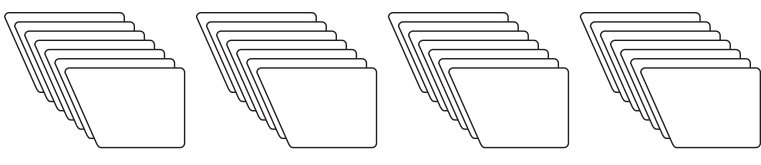

Keyhole slots have been provided in the back of your unit. If you wish to hang the unit, this sheet should be turned side ways so that it may be used as a template to locate your hanger positions.

