

KNOCK DOWN CABINET INSTRUCTIONS

Please review all parts in package. Each part has been labeled to help make assembly easy.
No tools needed for assembly.

PART NUMBER	DESCRIPTION	QUANTITY
1	LOWER LEFT SIDE	1
2	LOWER RIGHT SIDE	1
3	UPPER LEFT SIDE	1
4	UPPER RIGHT SIDE	1
5	LOWER BACK	1
6	UPPER BACK	1
7	SHELF	7
	1/4 - 20 X 1/2 PAN HEAD SCREWS	22

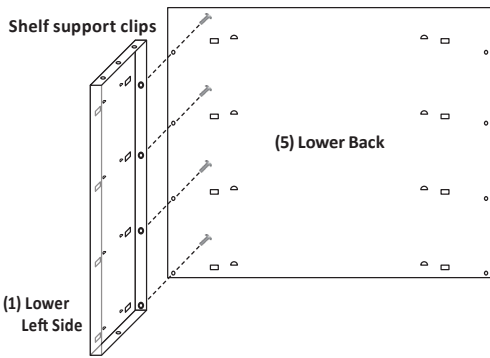

1 Begin by locating Part #1 lower left side and Part #5 lower back. Align the machined holes making sure the **shelf support clips are facing up**. Locate the weld nuts on Part #1 lower left side, secure Part #5 lower back using 4 pan head screws.

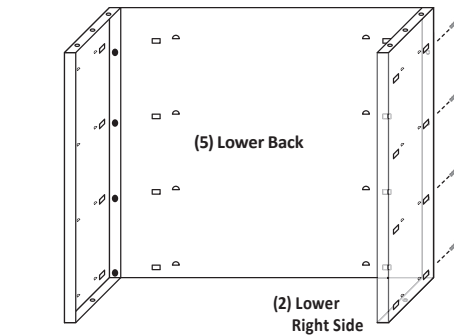

2 Align Part #2 lower right side to Part #5 lower back using 4 pan head screws.

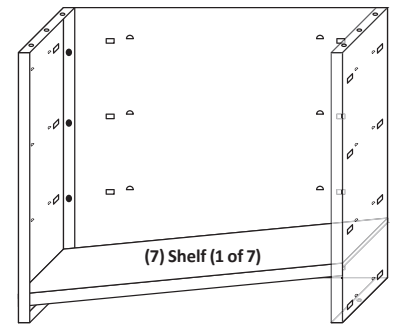

3 Place Part #7 shelf into the bottom row of shelf supports, by placing on an angle as shown, lift right side above support and push down. *Make sure the shelf is secured in all six support clips.*

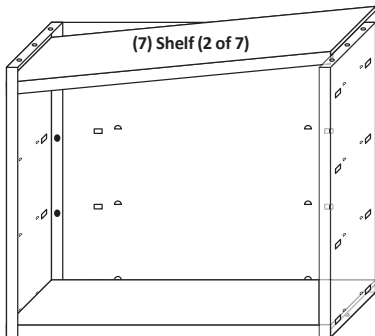

4 Place second shelf onto the top row of shelf support clips. This should be done on an angle, same as the previous step.

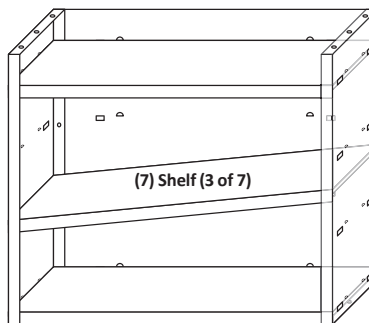

5 Place the third shelf on the shelf support clips following the same process as step 4.

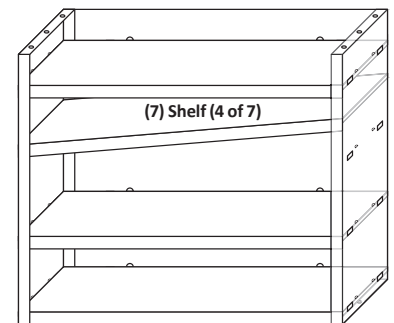

6 Place the fourth shelf on the shelf support clips following the same process as step 5.

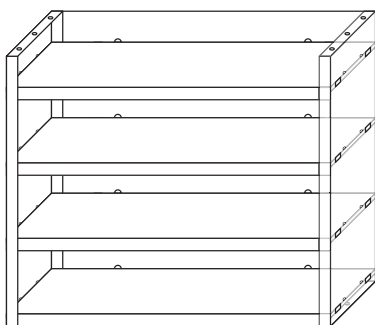

7 The lower section is now complete. Move onto the assembly of the upper section.

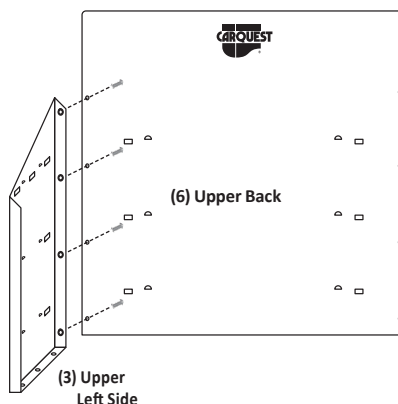

8 Align Part #3 upper left side and Part #6 upper back using 4 pan head screws.

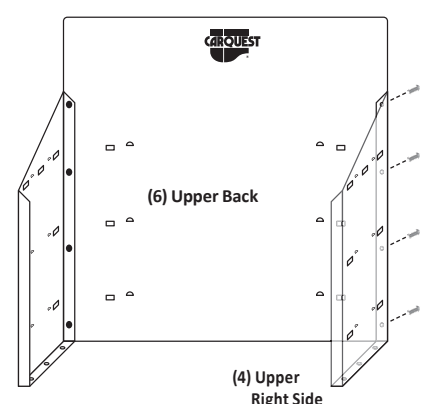

9 Repeat the same process align Part #4 upper right side to Part #6 upper back using 4 pan head screws.

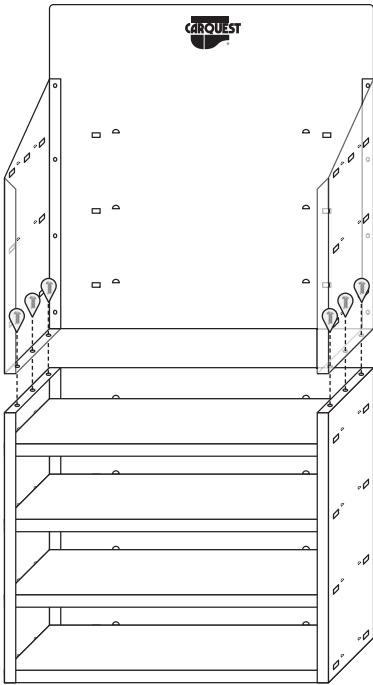

- 10** With assistance from a second person, grab the upper section from the side and the back and place on top of the lower section. Secure the top section to the bottom section using 6 pan head screws.

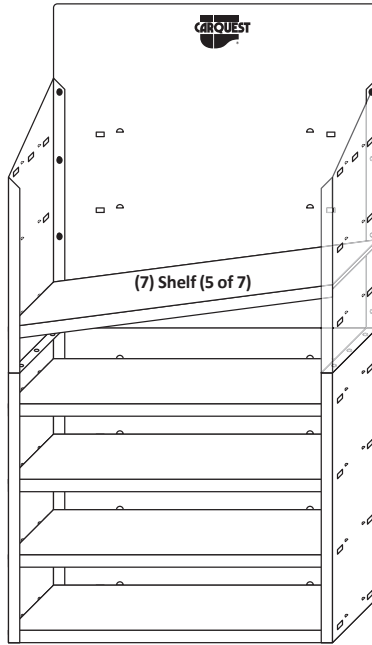

- 11** Place Part #7 shelf into the bottom row of shelf supports, by placing on an angle as shown, lift right side above support clips and push down. *Make sure the shelf is secured in all six support clips.*

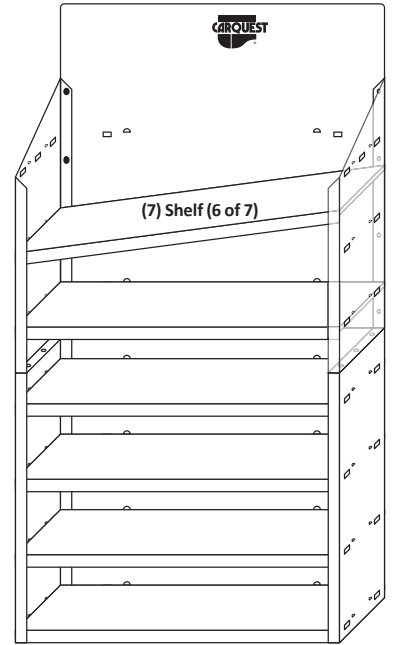

- 12** Place the second Part #7 shelf on the shelf support clips following the same process as step 11.

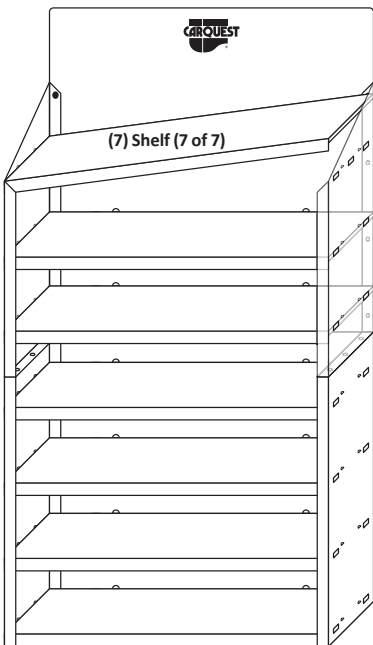

- 13** Place the third Part #7 shelf on the shelf support clips following the same process as step 12.

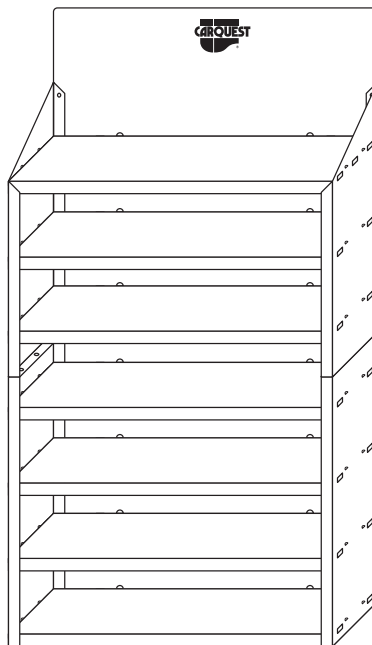

COMPLETE!